

K-Shear[®] Accelerometer

Type 8712A5M1

High Sensitivity, Voltage Mode Accelerometer

High 1000 mV/g sensitivity accelerometer measures low amplitude vibrations on large structures. Featuring a rugged all welded, hermetic construction with an electrical ground isolation, the accelerometer Type 8712A... is ideally suited for accurate long term measurements while subjected to adverse environments.

- Low impedance voltage mode
- Very high sensitivity
- Quartz shear accuracy and stability
- High immunity to thermal transients
- Ground isolated
- Welded hermetic construction
- Conforming to CE

Description

Utilizing Kistler's exclusive K-Shear design, the accelerometer exhibits very low sensitivity to base strain, thermal transients and transverse acceleration. In addition to the shear quartz elements contained within the housing, a Piezotron[®] micro-electronic circuit converts the high impedance charge signal emanating from a pair of elements into voltage signal. The low impedance voltage output minimizes noise pick-up and eliminates the need for highly insulated low noise cables. The electrically isolated base prevents potential ground loop problems. Quartz sensing elements afford the ultimate in long-term stability which ensures repeatable and accurate measurements for many years.

Application

The Type 8712A... is ideally suited for applications involving low amplitude vibrations over a wide frequency range. Examples include heavy structures, suspension building and machines. For permanent installation, Kistler offers a cable with a connector that can be factory welded (Type 1939) to the connector Type 8712A... . See the ordering key for details.

Mounting

Reliable and accurate measurements require that the mounting surface be clean and flat. The sensor can be attached to the structure by a single 1/4-28 mounting stud. The operating instruction manual for the Type 8712A... provides detailed information regarding mounting surface preparation.

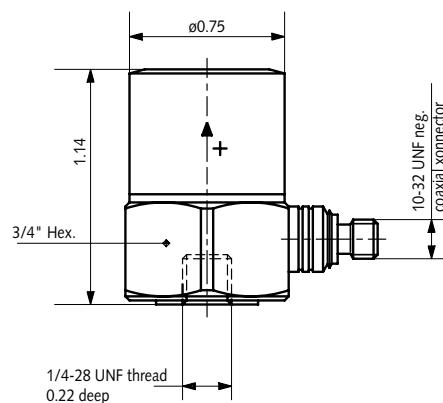

8712A_000-244a-05.08

Technical Data

Specification	Unit	Type 8712A5M1
Acceleration range	g	±5
Acceleration limit	gpk	±50
Transverse acceleration limit	gpk	±100
Threshold (noise 400 µVrms), nom.	grms	0.0004
Sensitivity, ±5 %	mV/g	1000
Resonant frequency mounted, nom.	kHz	24
Frequency response, ±5 %	Hz	0.5 ... 8000
Amplitude non-linearity	%FSO	±1
Time constant, nom.	s	1
Transverse sensitivity, nom. (max. 3)	%	1.5
Long term stability	%	±1

Environmental

Base strain sensitivity @ 250 µε	g/µε	<0.002
Shock limit (1 ms pulse)	gpk	1000
Temperature coefficient of sensitivity	%/°F	-0.03
Operating temperature range	°F	-65 ... 210
Storage temperature range	°F	-100 ... 300

Output

Bias, nom.	VDC	11
Impedance	Ω	<100
Voltage full scale	V	±5
Current	mA	2

Source

Voltage	VDC	20 ... 30
Constant current	mA	4
Impedance, min.	kΩ	>100

Construction

Sensing element	Type	quartz-shear
Case/base	material	stainless steel
Degree of protection case/connector	Type	hermetic
Connector	Type	10-32 neg.
Ground isolated		yes
Mass	grams	51
Mounting (1/4-28 thdx0.22 dp)	Type	stud
Mounting torque	lbf-in	18

1 g = 9.80665 m/s², 1 inch = 25.4 mm, 1 gram = 0.03527 oz, 1 lbf-in = 0.113 N·m

Included Accessories

	Type
• Mounting stud 1/4-28 to 10-32	8432
• Mounting stud 1/4-28	8412
• Mounting stud 1/4-28 to M8; shipped only outside N.A.	8421

Ordering Key

Range	Type 8712A
±5 g	5M1

Measuring Chain

	Type
1 Low impedance sensor	8712A...
2 Sensor cable, 10-32 pos. to BNC pos.	1761B...
3 Power supply/signal conditioner	51...
4 Output cable, BNC pos. to BNC pos.	1511

